

**NEW Cost Saving**  
**Integral Bushing/Studded Wheels**

# BISHOPWISECARVER<sup>®</sup>

**DUAL VEE**<sup>®</sup>

single edge slide  
system

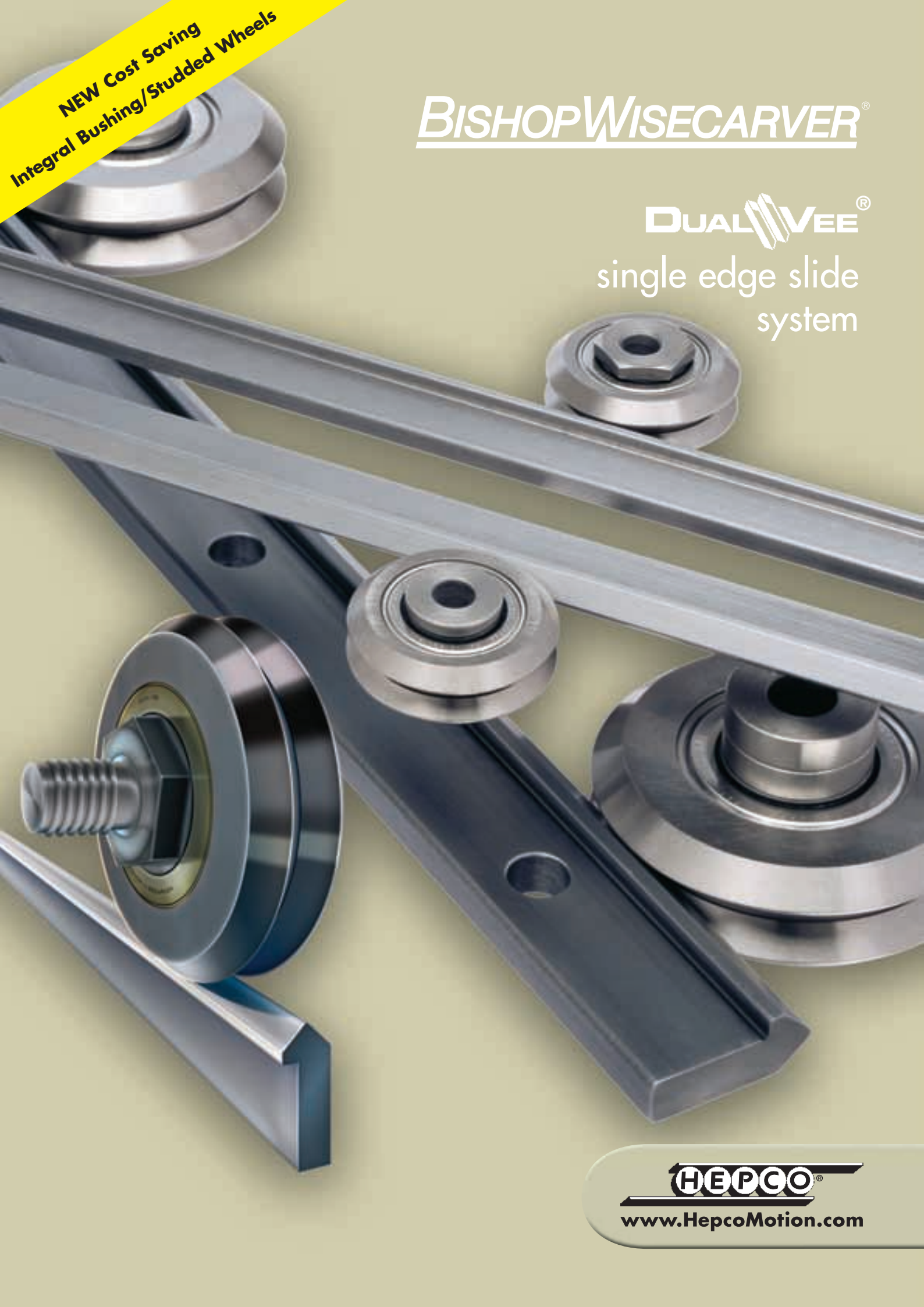

**HEPCO**<sup>®</sup>  
[www.HepcoMotion.com](http://www.HepcoMotion.com)

<b>Introducing DualVee Motion Technology®</b> .....	<b>1</b>
<b>Guide Wheel Overview</b> .....	<b>2</b>
<b>Guide Wheels</b> .....	<b>3</b>
<b>Guide Wheel Dimensions and Materials (Steel and Stainless Steel)</b> .....	<b>4</b>
<b>Integral Bushing DualVee Wheels</b> .....	<b>5</b>
<b>Integral Studded DualVee Wheels</b> .....	<b>6</b>
<b>Studded Guide Wheels Assembly</b> .....	<b>7</b>
<b>Crown Integral Studded Wheels, Steel and Polymer</b> .....	<b>8</b>
<b>Track: Sizes and Specifications</b> .....	<b>9</b>
<b>Single Edge Track – Drilled</b> .....	<b>10</b>
<b>Double Edge Track – Size 0 Drilled and Undrilled</b> .....	<b>11</b>
<b>Support Bushings – Standard Profile</b> .....	<b>12</b>
<b>Support Bushings – Low Profile</b> .....	<b>13</b>
<b>Wheel Cover Assemblies</b> .....	<b>14</b>
<b>Lubricator Assemblies</b> .....	<b>15</b>
<b>Mounting Dimensions</b> .....	<b>16</b>
<b>DualVee – Overview</b> .....	<b>17-20</b>
<b>Quick Ordering Procedure/Full Size Drawings</b> .....	<b>21</b>
<b>MinVee</b> .....	<b>22-24</b>

# Introducing DualVee Motion Technology®

DualVee Motion Technology® (DMT) includes a wide range of components and guide wheels which are used in the construction of antifriction, linear guidance mechanisms. DMT is a rugged yet cost effective linear bearing technology and is available in various options to suit a wide range of applications. Light duty applications in clean rooms to rugged transport systems working in hostile conditions can all benefit from DMT technology.



## **Specify with confidence**

*The DualVee product is built on a foundation of total quality, in-service reliability, sound application knowledge and customer satisfaction, spanning over 40 years.*

*DualVee is the original single edge slide system, having a proven track record in many thousands of applications world-wide across a broad range of industrial applications.*

## **DualVee Features and Benefits**



CAD CD available

- **PROVEN TECHNOLOGY/HIGH RELIABILITY**
- **BROAD PRODUCT RANGE**
- **FLEXIBILITY AND SIMPLICITY IN DESIGN**
- **LOW INSTALLED COST**
- **SMOOTH, ANTI-FRICTION OPERATION**
- **LOW NOISE/LOW VIBRATION**
- **HIGH SPEED CAPACITY**
- **IMPERVIOUS TO CONTAMINATED ENVIRONMENTS**
- **LONG STROKE LENGTHS**
- **EASY INSTALLATION AND MAINTENANCE**
- **LOW PROFILE**

## Guide Wheel Overview

- Double row angular contact bearing arrangement
- Available in six standard sizes
- Stainless or carbon steel configurations available from stock
- Clean room and high temperature configurations
- Available either shielded or sealed to accommodate required level of protection
- Either inside or outside Vee surface can be employed to support loads.

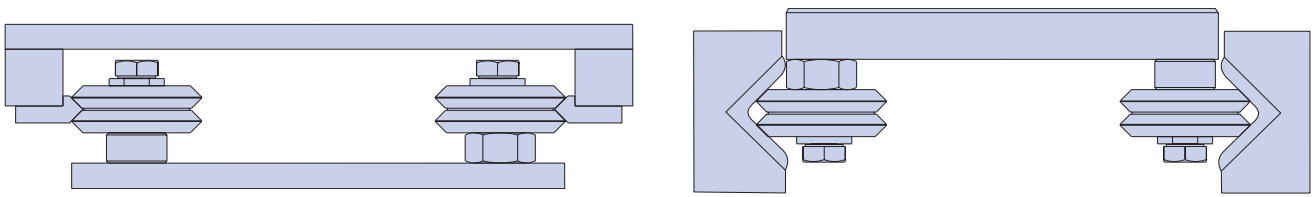

**Figure 1** DualVee configurations showing use of inside and outside Vee surfaces.



**Figure 2** DualVee Motion Technology® (left) vs. alternative recirculating bearing technologies (right).

### Notes:

Recirculating elements in DualVee guide wheels are self-contained and isolated from the environment; rolling contact between wheel and track sweeps debris aside making DualVee ideal for use in contaminated applications.

Alternative round and square rail linear guides have recirculating elements directly in contact with the rail's bearing surface, making shielding of the ball path region difficult; these alternative bearing technologies often require bellows or other costly methods of protection to prevent the ingress of contaminants which leads to catastrophic failure.

## Guide Wheels

### DualVee Steel and Stainless Steel Wheels (see note 2)

Part Number	Radial Load (N)	Axial Load (N)	Weight in Grams
W0	650	123	5.1
W1	1220	252	11.1
W2	2650	625	39.0
W3	5900	1701	130.2
W4	9700	4001	276.0
W0X	650	123	5.1
W1X	1220	252	11.1
W2X	2650	625	39.0
W3X	5900	1701	132.0
W4X	9700	4001	276.0
W4XXL	14300	6552	575.0
W1SSX	1220	252	11.1
W2SSX	2650	625	39.0
W3SSX	5900	1701	130.2
W4SSX	9700	4001	276.0
W4SSXXL	14300	6552	575.0
W0SSCR	540	102	5.1
W1SS227	1013	209	11.1
W2SS227	2200	519	39.0
W3SS227	4897	1412	130.2
W4SSCR	8051	3321	276.0

### DualVee Integral Bushing Wheels, Studded Wheels, Steel and Stainless Steel

Part Number	Radial Load (N)	Axial Load (N)	Weight in Grams
BWIC2/BWIE2	2650	625	45.0
BWIC3/BWIE3	5900	1701	156.4
BWIC4/BWIE4	9700	4001	302.0
SWIC0/SWIE0/SWAC0/SWAE0	650	123	9.1
SWIC1/SWIE1/SWAC1/SWAE1	1220	252	17.5
SWIC2/SWIE2/SWAC2/SWAE2	2650	625	54.3
SWIC3/SWIE3	5900	1701	164.0
SWIC4/SWIE4	9700	4001	330.4

### DualVee Polymer Studded Wheels

Part Number	Radial Load (N)	Axial Load (N)	Weight in Grams
SWIC0P/SWIE0P	28	12	5.9
SWIC1P/SWIE1P	55	27.5	10.7
SWIC2P/SWIE2P	70	42	26.2

### Crown Wheel, Steel and Polymer overmolded

Part Number	Radial Load (N)	Axial Load (N)	Weight in Grams
CSWIC0/CSWIE0	650	0	9.1
CSWIC1/CSWIE1	1220	0	25.0
CSWIC2/CSWIE2	2650	0	65.0
CSWIC3/CSWIE3	5900	0	190.0
CSWIC0P/CSWIE0P	28	0	6.2
CSWIC1P/CSWIE1P	55	0	11.2
CSWIC2P/CSWIE2P	70	0	27.5

#### Notes:

1. See page 17 for overview of load/life relationship.
2. Wheels on their own ('W' part numbers) will require Support Bushings, refer to pages 12/13.

# Guide Wheel Dimensions and Materials (Steel and Stainless Steel)

## Model Code Examples:

**W1** (DualVee Guide Wheel, Size 1, Standard Material, Shield)

**W1SSX** (DualVee Guide Wheel, Size 1, Stainless Steel, Seal)

## Support Bushings – see page 12/13

Wheel DualVee	Wheel Size	Materials	Outer Race	Inner Race	Ball	Retainer	Shield or Seal	
<b>W</b>	<b>0</b>	<b>Blank (Std.)=</b>	52100	52100	52100	Nylon 66	Shield	
		<b>X=</b>	52100	52100	52100	Nylon 66	Seal	
		<b>SSCR=</b>	440C	440C	440C	304	Seal	
	SSCR (Clean Room Compatible <sup>4</sup> )							
	<b>1</b>	<b>2</b>	<b>Blank (Std.)=</b>	52100	52100	52100	Nylon 66	Shield
			<b>X=</b>	52100	52100	52100	Nylon 66	Seal
			<b>SSX=</b>	440C	440C	440C	Nylon 66	Seal
			<b>SS227=</b>	440C	440C	440C	304	Shield
	SS227 (Heat Stabilized for Clean Room and High Heat Compatible <sup>5</sup> )							
	<b>3</b>	<b>4</b>	<b>Blank (Std.)=</b>	52100	52100	52100	Nylon 66	Shield
			<b>X=</b>	52100	52100	52100	Nylon 66	Seal
			<b>SSX=</b>	440C	440C	440C	Nylon 66	Seal
			<b>SS227=</b>	440C	440C	440C	304	Shield
	SS227 (Heat Stabilized for Clean Room and High Heat Compatible <sup>5</sup> )							
	<b>4</b>	<b>4</b>	<b>Blank (Std.)=</b>	52100	52100	52100	Nylon 66	Shield
			<b>X=</b>	52100	52100	52100	Nylon 66	Seal
			<b>SSX=</b>	440C	440C	440C	Nylon 66	Seal
			<b>SSCR=</b>	440C	440C	440C	304	Seal
SSCR (Clean Room Compatible <sup>4</sup> )								
<b>4XXL</b> Extra Large Wheel	<b>4XXL</b>	<b>XXL=</b>	52100	52100	52100	Nylon 66	Seal	
		<b>SSXL=</b>	440C	440C	440C	Nylon 66	Seal	

Size	Outside Diameter A	Bore Size B <sup>1,2</sup>	Width W <sup>3</sup>	Inside Vee Radius MD <sub>w</sub> Inside	Outside Vee Radius MD <sub>w</sub> Outside
0	14.83	4.00	6.35	5.94	9.12
1	19.58	4.76	7.87	7.95	11.89
2	30.73	9.53	11.13	12.70	18.26
3	45.80	12.00	15.88	19.05	27.00
4	59.94	15.00	19.05	25.40	34.93
4XXL	75.39	22.00	25.40	31.75	44.45

\* All dimensions are in mm. \*\* Guide wheels are manufactured to ABEC 1.

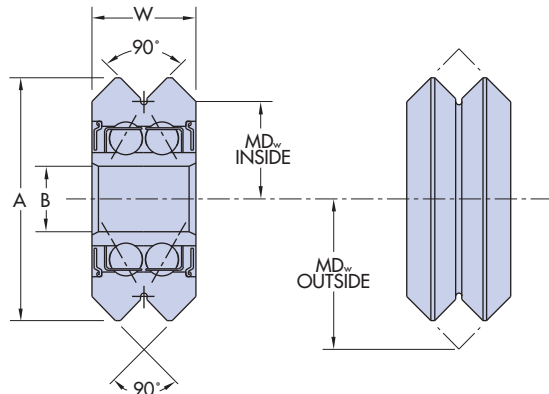
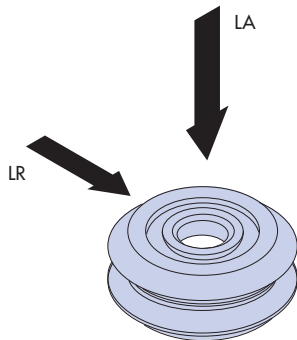

### Notes:

- Bore ID tolerance is +0-0.007, except 4XXL.
- 4XXL Bore ID tolerance is +0-0.01.
- Width tolerance is +0-0.12.
- Clean Room Compatible – All stainless steel components are internally lubricated with Krytox GPL 227.
- High Temperature Compatible – Heat stabilized components allow for operating temperatures to 260°C.

# Integral Bushing DualVee Wheels

**\*Lower cost than wheel with separate bush**

## Model Code Examples:

**BWIC2M** (Bushing DualVee Wheel Integral, Concentric, Size 2, Standard Material)

**BWIE2SSXM** (Bushing DualVee Wheel Integral, Eccentric, Size 2, Stainless Steel)

Bushing Wheel Integral	Wheel Offset	Wheel Size	Materials Code	Outer Race	Inner Race	Ball	Retainer	Shield or Seal	Thru-Bore
<b>BWI</b>	<b>C</b> =Concentric <b>E</b> =Eccentric	2	Blank (Std.)=	52100	52100	52100	Nylon 66	Shield	M=Metric Straight
		3	X=	52100	52100	52100	Nylon 66	Seal	
		4	SSX'=	440C	440C	440C	Nylon 66	Seal	

Size	A	BØ	C	D	E	FØ
2	14	8	9.63	15.19	0.76	30.73
3	19	10	13.63	21.56	1.50	45.80
4	22	12	16.36	25.88	2.01	59.94

\* All dimensions are in mm.

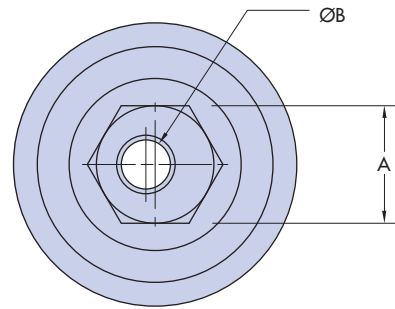
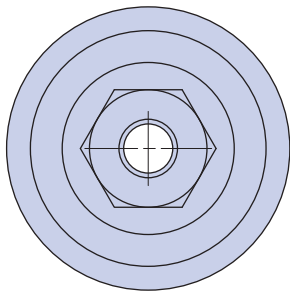

Concentric

Eccentric

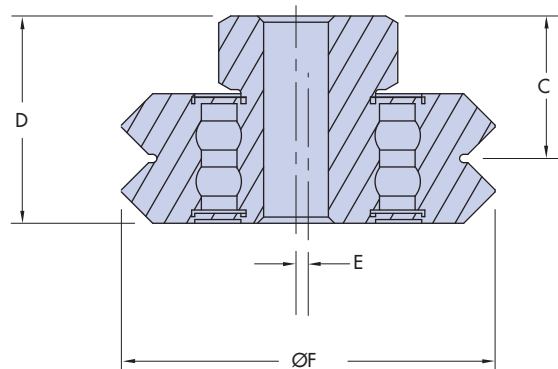
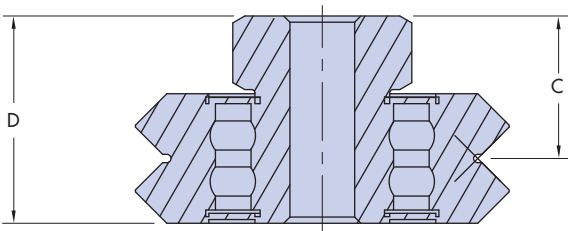

# Integral Studded DualVee Wheels

## Model Code Examples:

**SWIC1** (Studded DualVee Wheel Integral, Concentric, Size 1, Standard Material)

**SWIE1P** (Studded DualVee Wheel Integral, Eccentric, Size 1, Polymer)

Studded Wheel Integral	Wheel Offset	Wheel Size	Materials Code			Materials									
				Outer Race	Inner Race	Ball	Retainer	Shield or Seal							
SWI	C=Concentric E=Eccentric	0	Blank (Std.)=	52100	52100	52100	Nylon 66	Shield							
			X=	52100	52100	52100	Nylon 66	Seal							
			SSX=	440C	440C	440C	Nylon 66	Seal							
		2	P=	Polymer Overmolded 440C	440C	440C	440C	Stainless Steel	Shield						
		3	Blank (Std.)=	52100	52100	52100	52100	Nylon 66	Shield						
										X=	52100	52100	52100	Nylon 66	Seal
										SSX=	440C	440C	440C	Nylon 66	Seal
		4	Blank (Std.)=	52100	52100	52100	52100	Nylon 66	Shield						
										X=	52100	52100	52100	Nylon 66	Seal

## Integrated Studded Steel Wheels

Size	A	B <sup>1</sup>	C <sup>2</sup>	D <sup>3</sup>	E	F <sup>4</sup>	G	Concentric Stud Thread	Eccentric Stud Thread	H	Internal Hex (steel version only)	I (max)
0	11	5.56	2.16	7.62	16.94	6.15	0.45	M6 x 1.0	M5x 0.8	14.83	-	0.43
1	12	6.35	2.16	8.10	19.34	7.30	0.60	M8 x 1.25	M6 x 1.0	19.58	-	0.5
2	14	9.53	2.79	11.38	26.57	9.63	0.76	M10 x 1.5	M8 x 1.25	30.73	6	-
3	19	10.72	4.32	15.11	36.67	13.63	1.49	M12 x 1.75	M10 x 1.5	45.80	8	-
4	22	12.70	4.50	19.00	44.88	16.36	2.00	M14 x 2.0	M12 x 1.75	59.94	10	-

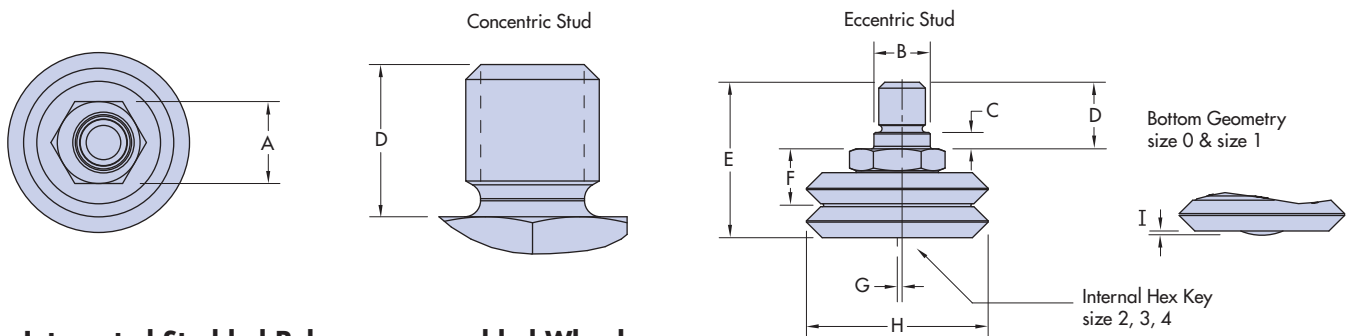

## Integrated Studded Polymer overmolded Wheels

Size	A	B <sup>1</sup>	C <sup>2</sup>	D <sup>3</sup>	E	F <sup>4</sup>	G	Concentric Stud Thread	Eccentric Stud Thread	H
0	11	5.56	2.16	7.62	16.94	6.15	0.81	M6 x 1.0	M5x 0.8	14.83
1	12	6.35	2.16	8.10	19.34	7.30	0.83	M8 x 1.25	M6 x 1.0	19.58
2	14	9.53	2.79	11.38	26.57	9.63	0.93	M10 x 1.5	M8 x 1.25	30.73

\* All dimensions are in mm.

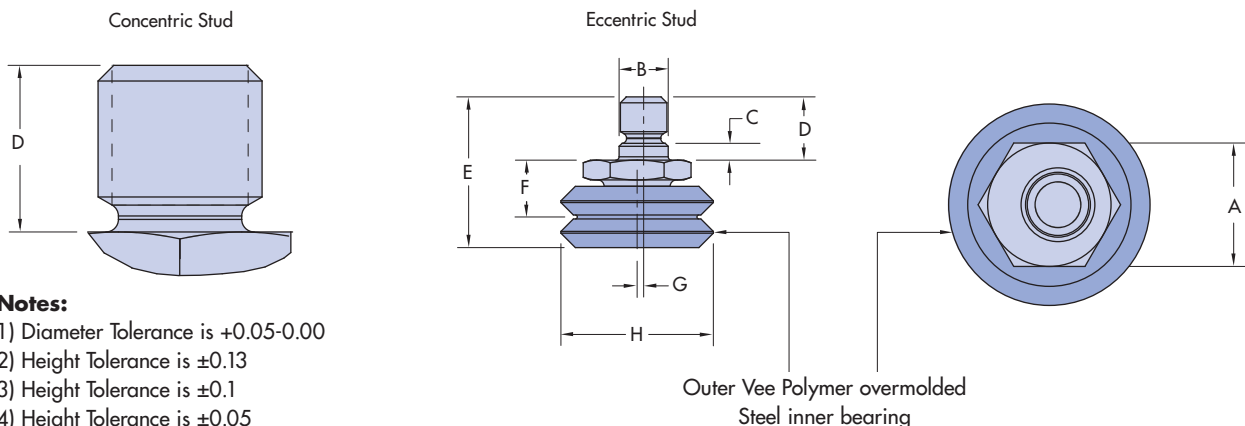

### Notes:

- 1) Diameter Tolerance is +0.05-0.00
- 2) Height Tolerance is ±0.13
- 3) Height Tolerance is ±0.1
- 4) Height Tolerance is ±0.05



# Studded Guide Wheels Assembly

## Model Code Examples:

**SWAC1** (Studded DualVee Wheel, Concentric Size 1, Standard Materials)

**SWAE1SSX** (Studded DualVee Wheel, Eccentric Size 1, Stainless Steel)

Studded Wheel Assembly	Wheel Offset	Wheel Size	Materials Code	Outer Race	Inner Race	Materials Ball	Retainer	Shield or Seal	
SWA	C=Concentric E=Eccentric	0	X=	52100	52100	52100	Nylon 66	Seal	
			SSCR=	440C	440C	440C	304	Seal	
	(Clean Room Compatible)								
	C=Concentric E=Eccentric	1	Blank (Std.)=	52100	52100	52100	Nylon 66	Shield	
			X=	52100	52100	52100	Nylon 66	Seal	
C=Concentric E=Eccentric	2	SSX=	440C	440C	440C	Nylon 66	Seal		
		SS227=	440C	440C	440C	304	Shield		
(Heat Stabilized for Clean Room and High Heat Compatible <sup>1</sup> )									

Size	Offset EC <sup>5</sup>	Overall Length E	H	Journal Diameter OD <sup>2</sup>	Journal Length JL	Thread Length TL	Thread T	Shoulder Thickness S <sup>3</sup>	Vee Height VH <sup>4</sup>	Hex Size HS	Nut & Washer N, W <sup>6,7</sup>	Weight in Grams
0	0.3	18.8	14.83	3.98	9.9	6.1	M4 x 0.7	2.0	5.2	11	M4	8.9
1	0.4	25.4	19.58	5.97	15.0	8.9	M6 x 1	2.1	6.0	12	M6	19.8
2	0.6	39.1	30.73	9.97	24.9	15.0	M10 x 1.5	2.6	8.2	14	M10	74.2

\* All dimensions are in mm.

## Thru-Hole Style

- DualVee® guide wheels with 416 stainless steel stud and mounting hardware
- Easy installation/available from stock
- Consolidates multiple components into one part number, making procurement simple
- Choose from a wide range of standard available guide wheels
- For larger wheel sizes in a studded configuration, contact the Hepco Sales Department

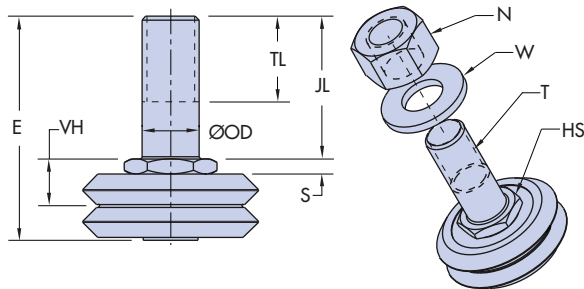

**Concentric**

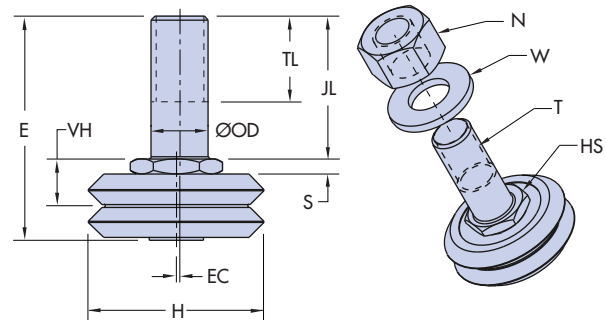

**Eccentric**

## Notes:

1. High Temperature compatible. Heat stabilized performance allows for operating temperatures to 260° C.
2. Journal Diameter (OD) Tolerance is +0.00-0.02.
3. Shoulder Thickness (S) Tolerance is ±0.03.
4. Vee Height (VH) Tolerance is ±0.05 mm.
5. Eccentricity (EC) Tolerance is ±0.13 mm. All mounting information in this catalogue assumes a central position of the eccentric stud allowing adjustment from plus "EC" to minus "EC".
6. Nuts are manufactured to DIN standard 934 (18-8 stainless steel).
7. Washers are manufactured to DIN standard 125 (18-8 stainless steel).
8. See guide wheel specifications for detailed data on wheels (page 4).
9. See load/life discussion in the technical reference section for sizing and selection information (page 17/18).

# Crown Integral Studded Wheels, Steel and Polymer

## Model Code Examples:

**CSWIC1** (Crown Wheel, Stud Integral, Concentric, Size 1, Standard Materials)

**CSWIE2P** (Crown Wheel, Stud Integral, Eccentric, Size 2, Polymer)

Wheel Style	Studded Wheel Integral	Wheel Offset	Wheel Size	Materials Code	Materials				
					Outer Race	Inner Race	Ball	Retainer	Shield
C = Crown	SWI	C= Concentric E= Eccentric	*0=14.83 dia.	Blank (Std.)=	52100	52100	52100	Nylon 66	Shield
			1=19.58 dia.	x=	52100	52100	52100	Nylon 66	Seal
			2=30.73 dia.	P =	Polymer Overmolded 440C	440C	440C	Stainless Steel	Shield
			3=45.80 dia.	Blank (Std.)=	52100	52100	52100	Nylon 66	Shield

\* Size 0 only available Polymer Overmolded

## Crown Integral Studded Wheels, Steel

Size	A	B <sup>1</sup>	C <sup>2</sup>	D <sup>3</sup>	E	F <sup>4</sup>	G	Concentric Stud Thread	Eccentric Stud Thread	H	Internal Hex (steel version only)	I (max)
1	12	6.30	2.16	8.10	19.34	7.30	0.60	M8 x 1.25	M6 x 1.0	19.58	-	0.5
2	14	9.53	2.79	11.38	26.57	9.63	0.76	M10 x 1.5	M8 x 1.25	30.73	6	-
3	19	10.72	4.32	15.11	36.67	13.63	1.49	M12 x 1.75	M10 x 1.5	45.80	8	-

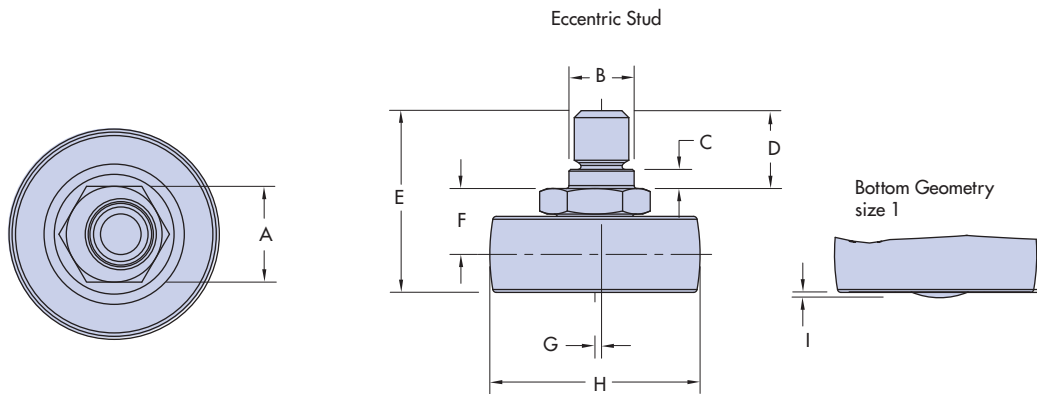

## Crown Integral Studded Wheels, Polymer Overmolded

Size	A	B <sup>1</sup>	C <sup>2</sup>	D <sup>3</sup>	E	F <sup>4</sup>	G	Concentric Stud Thread	Eccentric Stud Thread	H	I (max)
0	11	5.56	2.16	7.62	16.94	6.15	0.81	M6 x 1.0	M5x 0.8	14.83	0.5
1	12	6.30	2.16	8.10	19.34	7.30	0.83	M8 x 1.25	M6 x 1.0	19.58	0.5
2	14	9.53	2.79	11.38	26.57	9.63	0.96	M10 x 1.5	M8 x 1.25	30.73	-

\* All dimensions are in mm.

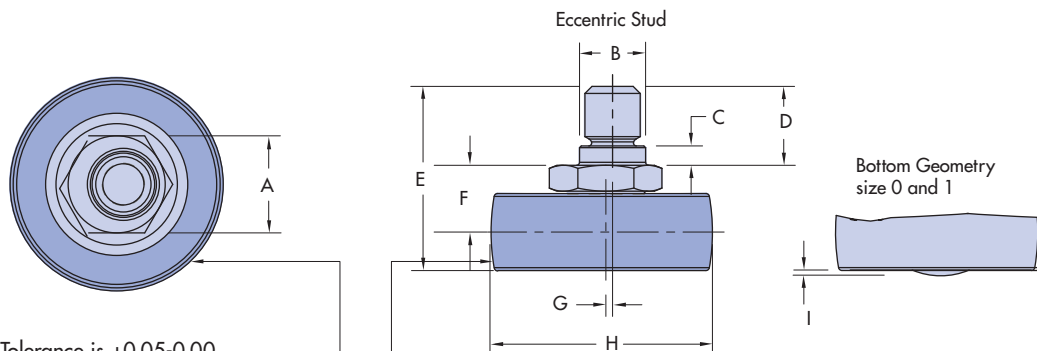

### Notes:

- 1) Diameter Tolerance is +0.05-0.00
- 2) Height Tolerance is ±0.13
- 3) Height Tolerance is ±0.1
- 4) Height Tolerance is ±0.05

Outer Race Polymer overmolded  
Steel inner bearing

## Track: Sizes and Specifications

### Single Edge Track – Undrilled

- Easy installation/available from stock
- Single edge design allows for flexible track pair spacing
- Patented mounting shoulder allows for accurate positioning of Vee ways
- Available “as formed,” or induction hardened and polished
- Induction hardened track remains soft below the mounting shoulder, allowing for drilling or other machining
- Available in either AISI 1045 carbon steel or 420 stainless steel
- Available undrilled or pre-drilled for ease of installation
- Can be easily butt-joined for stroke lengths exceeding maximum single piece lengths (6096mm). Maximum Single length available 6096mm (except T4SS maximum length 5790mm). Any length cut to a tolerance of  $\pm 1.5\text{mm}$ . (Cutting charge applies.)

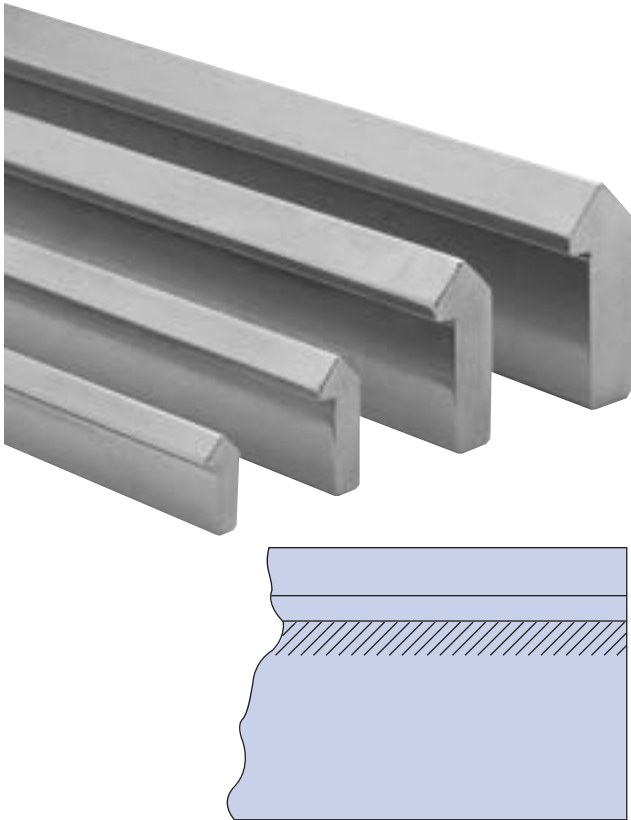

**To order:** Specify number of lengths, type of track, size, length.

**Example:** 5 ea., T4 1500mm (5 pieces, hardened track, size #4, 1.5m long).

**Notes:**

1. All dimensions are in mm.

**Specifications:**

- TS** Material AISI 1045 steel, cold formed to shape, unhardened, oiled.
- TS SS** Material AISI 420 series stainless steel, cold formed to shape, unhardened, oiled.
- T** Material AISI 1045 steel, top contact surfaces hardened 53 Rockwell C minimum, polished, oiled. Portion below indexing shoulder is left soft so it may be drilled for mounting.
- T SS** Material AISI 420 series stainless steel, top contact surfaces hardened 40 Rockwell C minimum. Portion below indexing shoulder is left soft so it may be drilled for mounting. To further enhance corrosion resistance the track can be treated with Hepco’s Pristinox™ process, which enriches the surface’s chromium properties. Contact HepcoMotion’s technical department for further information.

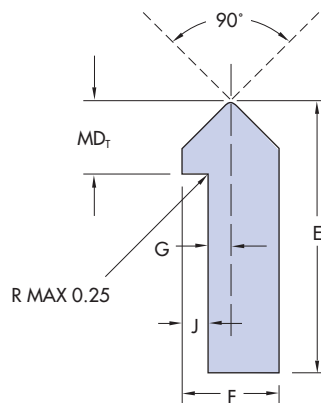

Size	E	F	G	J	MD <sub>r</sub>	Kg/m
1	11.09	4.74	0.78	1.57	3.17	0.272
2	15.87	6.35	0.78	2.36	4.75	0.509
3	22.22	8.71	1.57	2.76	6.35	1.02
4	26.97	11.09	2.36	3.17	7.92	1.63

# Single Edge Track - Drilled

DualVee Size	Part Number	Number of Holes	Length L <sup>7</sup>	End Hole Spacing ES <sup>4</sup>	Hole to Hole Spacing HS <sup>3</sup>	Hole Size Thru (Diameter) MH <sup>5</sup>	Mounting Hole Location MHL <sup>6</sup>
1	T1-311-7	7	311	20.5	45	4.5	4.0
	T1-581-13	13	581				
	T1-851-19	19	851				
	T1-1121-25	25	1121				
	T1-1391-31	31	1391				
	T1-1661-37	37	1661				
2	T2-446-5	5	446	43	90	6.0	5.6
	T2-806-9	9	806				
	T2-1166-13	13	1166				
	T2-1526-17	17	1526				
	T2-1886-21	21	1886				
	T2-2246-25	25	2246				
3	T3-446-5	5	446	43	90	8.0	8.0
	T3-806-9	9	806				
	T3-1166-13	13	1166				
	T3-1526-17	17	1526				
	T3-1886-21	21	1886				
	T3-2246-25	25	2246				
4	T4-446-5	5	446	43	90	9.5	9.5
	T4-806-9	9	806				
	T4-1166-13	13	1166				
	T4-1526-17	17	1526				
	T4-1886-21	21	1886				
	T4-2246-25	25	2246				

\* All dimensions are in mm.

## Part Numbering

- T\_XXXXY**      AISI 1045 carbon steel hardened to a minimum of Rc 53, polished and oiled
- TS\_XXXXY**     AISI 1045 carbon steel unhardened (Rc 22-25), as formed, oiled
- T\_SS-XXXXY**    AISI 420 stainless steel hardened to a minimum of Rc 40, polished and oiled
- TS\_SS-XXXXY**    AISI 420 stainless steel unhardened (Rc 20-22), as formed, oiled

The underscore must be filled in with the appropriate DualVee track size (1, 2, 3, or 4)  
**XXXX = (dimension L)    Y = the total number of holes in the track**

## Examples

T3-2246-25 represents a size 3 track, carbon steel hardened, 2246mm long, with a total of 25 holes along the length  
 TS2SS-446-5 represents a size 2 track, stainless steel unhardened, 446mm long, with a total of 5 holes along the length

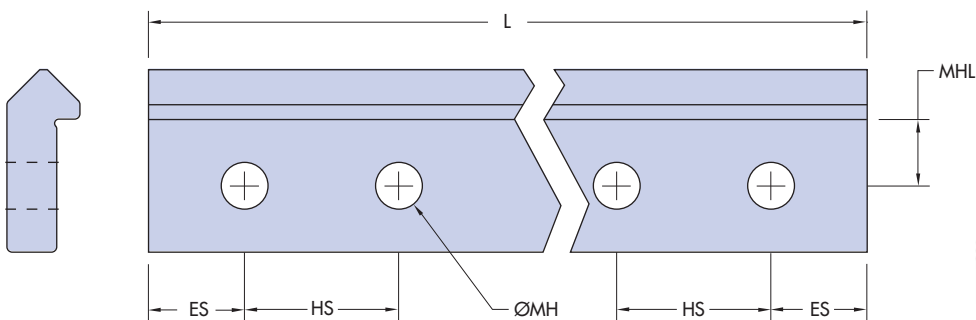

## Notes:

1. Available coating/plating options include black oxide or thin dense chrome. SS Track available with Pristinox™ process (see page 9).
2. Non-standard hole patterns can be accommodated. Non-standard track options are quoted upon request.
3. Hole to hole spacing tolerance is  $\pm 0.2$  non-cumulative (dimension HS).
4. End hole spacing tolerance is  $\pm 0.5$  (dimension ES).
5. Hole diameter tolerance is  $\pm 0.1$ .
6. Mounting hole location (MHL) tolerance is  $\pm 0.050$ .
7. Maximum single piece track lengths: 6m

## Double Edge Track – Size 0 Drilled and Undrilled

- Patented mounting shoulder to accurately position Vee ways
- Double edge design ensures parallel Vee ways
- Pre-drilled track, immediate installation, no machining required
- AISI 1045 carbon steel, hardened (Rc 53), polished, oiled (TDO)
- AISI 1045 carbon steel, unhardened (Rc 22-25), as formed, oiled (TDS0)
- Available coating/plating options: black oxide or thin dense chrome

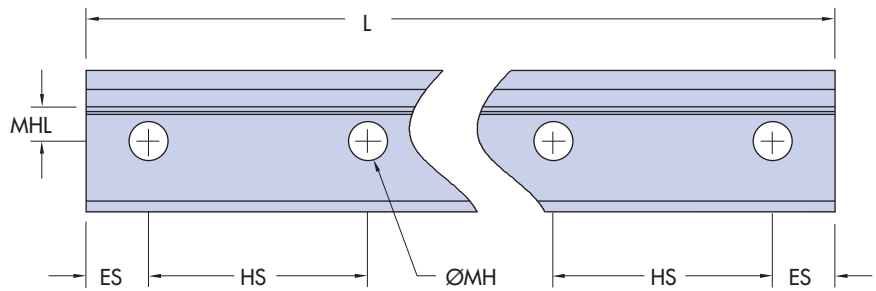
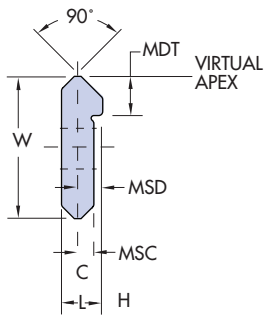
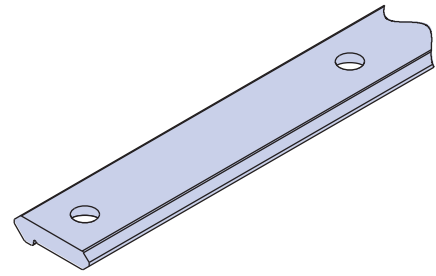

### Standard Drilled Track

Part Number	Number of Holes	Length	Vee Way Surface Condition	Vee Way Surface Hardness	Hole Spacing	End Hole Spacing	Hole Size (Thru)	Hole Location
				Rockwell C				
TDO-155-4	4	155	Hardened	RC 53 Minimum	45	10	4.0	3.50
TDO-290-7	7	290						
TDO-425-10	10	425						
TDO-560-13	13	560						
TDO-695-16	16	695						
TDO-830-19	19	830	Unhardened	RC 22-25	45	10	4.0	3.50
TDS0-155-4	4	155						
TDS0-290-7	7	290						
TDS0-425-10	10	425						
TDS0-560-13	13	560						
TDS0-695-16	16	695						
TDS0-830-19	19	830						

### Undrilled Track<sup>2</sup>

DualVee Size	Part Number	Width	Height Location	Mounting Shoulder Centre Line	Mounting Shoulder to Depth	Mounting Shoulder to	Weight (kg/m)	Condition Hardness	Vee Way Surface
		W	H	MDT	MSC	MSD			Rockwell C
0	TDO	13.10	3.88	4.01	1.52	0.84	0.25	Hardened	Rc 53 min
0	TDS0	13.10	3.88	4.01	1.52	0.84	0.25	Unhardened	Rc 22-25

#### Notes:

1. For non-standard track lengths or other non-standard options, contact HepcoMotion for quotation.
2. Maximum single piece track lengths: 6m.
3. All tolerances same as single edge track, see page 10.
4. See pages 4, 22/23 for wheel (0) and MinVee Wheel Carriage details.

## Support Bushings – Standard Profile

- Rigidly affixes guide wheels to a mounting surface precisely
- Material options include 303 stainless steel or nickel plated carbon steel<sup>2</sup>
- Concentric<sup>6</sup> and eccentric<sup>4</sup> configurations allow for system adjustment
- Customer to supply screw/bolt to fix wheel bush assembly to mounting surface
- Standard and low profile head height configurations are available to suit space requirements

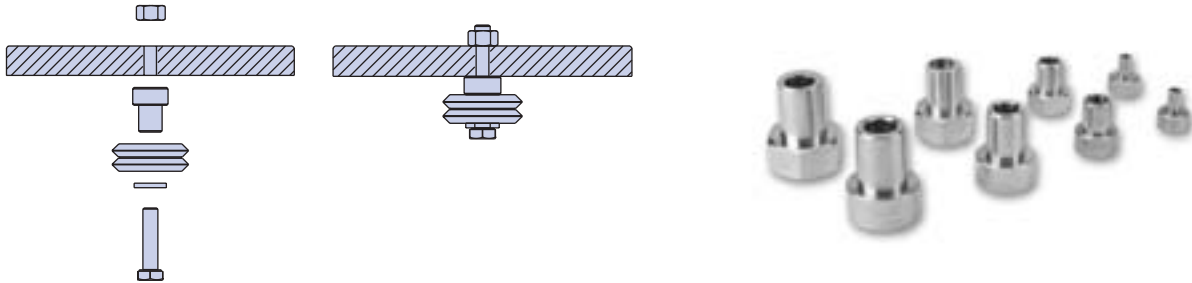

SUPPORT BUSHINGS STANDARD PROFILE DIMENSIONS <sup>1</sup>										
DualVee Size	Part Number	Recommended Fastener Size	Hex Size HS	Offset EC <sup>5</sup>	Head Height HH <sup>7</sup>	Length Body LB	Length Overall LO	Outside Diameter OD <sup>3</sup>	Inside Diameter ID	Head Diameter HD
1	MB1	M4	-	-	6.22	7.6	13.8	4.76	4.0	11.2
1	MBX1	M4	12	0.25	6.22	7.6	13.8	4.76	4.0	-
2	MB2	M6	-	-	6.65	10.8	17.4	9.52	6.0	14.2
2	MBX2	M6	14	0.61	6.65	10.8	17.4	9.52	6.0	-
3	MB3	M8	-	-	9.47	15.6	25.1	11.99	8.0	19.1
3	MBX3	M8	19	1.07	9.47	15.6	25.1	11.99	8.0	-
4	MB4	M10	-	-	11.10	18.8	29.9	15.00	10.0	22.4
4	MBX4	M10	22	1.52	11.10	18.8	29.9	15.00	10.0	-
4XL	MB4XL	M14	-	-	14.35	25.1	39.5	21.97	14.0	31.8
4XL	MBX4XL	M14	30	1.52	14.35	25.1	39.5	21.97	14.0	-

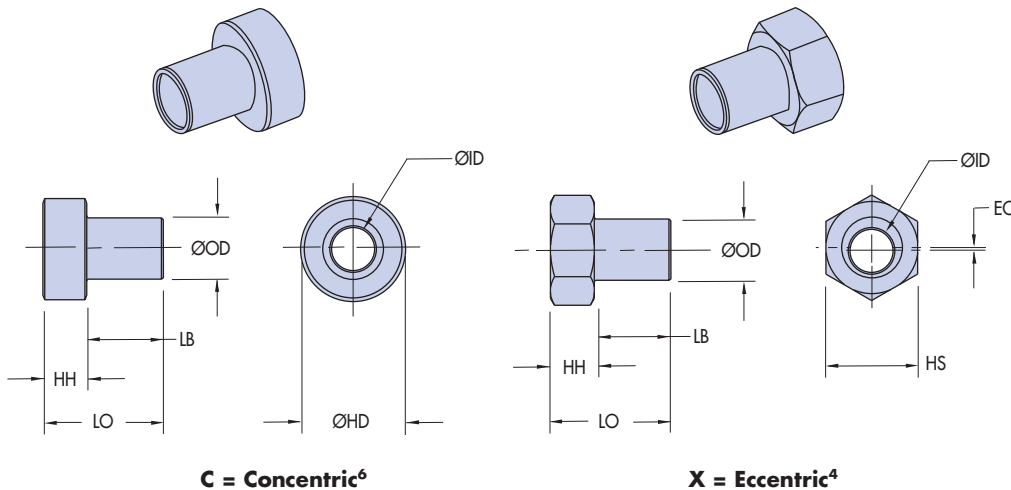

### Notes:

1. All dimensions are in mm.
2. Standard materials are electroless nickel plated carbon steel or 303 stainless steel. Add "-SS" to the end of the part number for stainless steel.
3. The bushing's outside diameter is designed to fit the corresponding size DualVee guide wheel.
4. Part #MBX\_ indicates eccentric (adjustable) bushing; rotation of eccentric allows adjustment between track and guide wheels.
5. All mounting information within this catalogue assumes a central position of the eccentric bushing, thus allowing wheel position adjustment from "+EC" to "-EC".
6. Part #MB\_ indicates concentric (stationary) bushing; Since concentrically mounted wheels have a fixed position, these bushings set the alignment of the carriage assembly to the rail. Concentrically mounted wheels should be configured to carry the majority of the load whenever possible.
7. Head Height (HH) Tolerance is  $\pm 0.05\text{mm}$ .

# Support Bushings – Low Profile

- Space saving
- Stainless Steel<sup>2</sup>

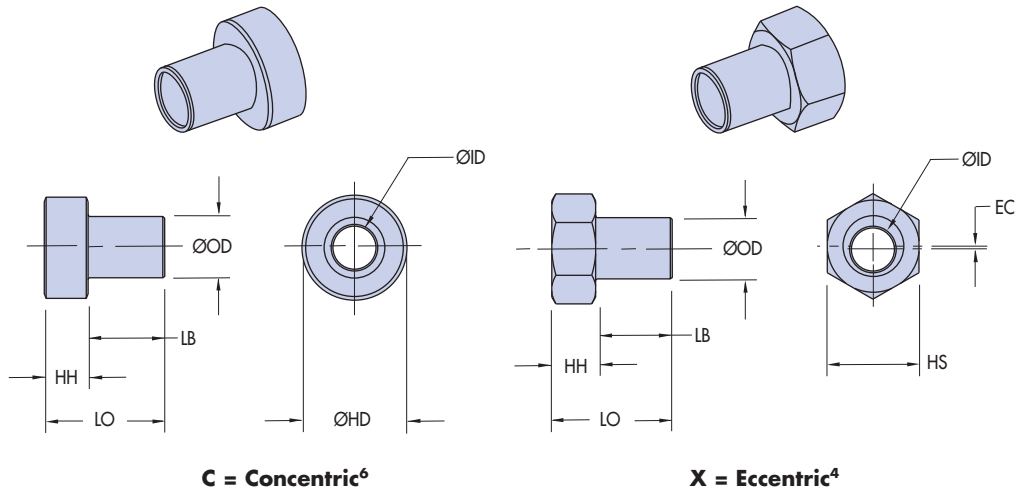

SUPPORT BUSHINGS LOW PROFILE DIMENSIONS <sup>1</sup>										
DualVee Size	Part Number	Recommended Fastener Size	Hex Size HS	Offset <sup>5</sup> EC	Head Height HH <sup>7</sup>	Length Body LB	Length Overall LO	Outside Diameter OD <sup>3</sup>	Inside Diameter ID	Head Diameter HD
1	M1PWBC	M4	-	-	2.11	7.6	9.7	4.76	4.0	11.2
1	M1PWBX	M4	12	0.18	2.11	7.6	9.7	4.76	4.0	-
2	M2PWBC	M6	-	-	2.64	10.8	13.4	9.52	6.0	14.2
2	M2PWBX	M6	14	0.61	2.64	10.8	13.4	9.52	6.0	-
3	M3PWBC	M8	-	-	3.48	15.6	19.1	11.99	8.0	19.1
3	M3PWBX	M8	19	1.07	3.48	15.6	19.1	11.99	8.0	-
4	M4PWBC	M10	-	-	3.10	18.8	21.9	15.00	10.0	22.4
4	M4PWBX	M10	22	1.52	3.10	18.8	21.9	15.00	10.0	-
4XL	M4XLPWBC	M14	-	-	5.10	25.1	30.3	21.97	14.0	31.8
4XL	M4XLPWBX	M14	30	1.52	5.10	25.1	30.3	21.97	14.0	-

**Notes:**

1. All dimensions are in mm.
2. Low profile support bushings are available in 303 stainless steel only.
3. The bushing's outside diameter is designed to fit the corresponding size DualVee guide wheel.
4. Part # M\_PWBX indicates eccentric (adjustable) bushing; rotation of eccentric allows adjustment between track and guide wheels.
5. All mounting information within this catalogue assumes a central position of the eccentric bushing, thus allowing wheel position adjustment from "+EC" to "-EC".
6. Part # M\_PWBC indicates concentric (stationary) bushing; Since concentrically mounted wheels have a fixed position, these bushings set the alignment of the carriage assembly to the rail. Concentrically mounted wheels should be configured to carry the majority of the load whenever possible.
7. Head Height (HH) Tolerance is ± 0.05mm.

# Wheel Cover Assemblies

- Protects the wheel/track contact region
- Sweeps aside debris that may collect on the track
- Continually dispenses a thin film of oil along the Vee way<sup>3</sup>
- Lubricating properties increase load capacity and service life
- Covers rolling element contact surface satisfying safety requirements<sup>2</sup>

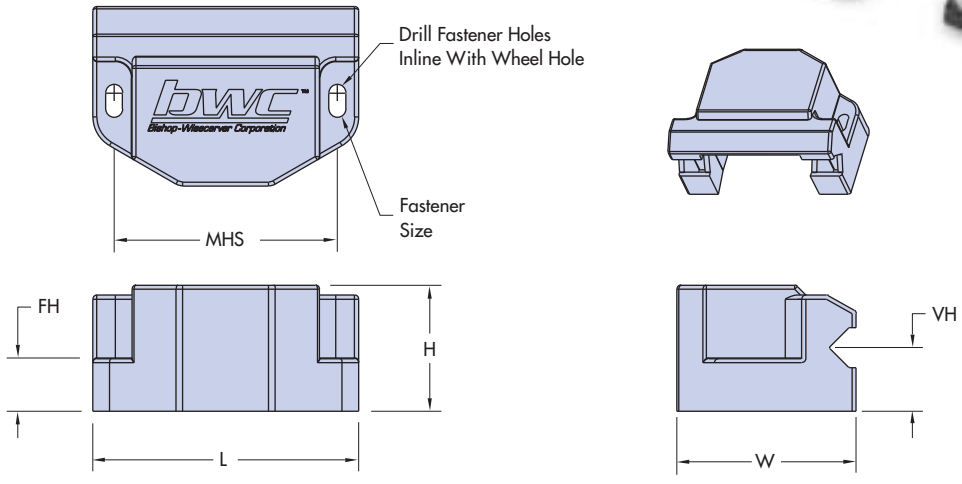
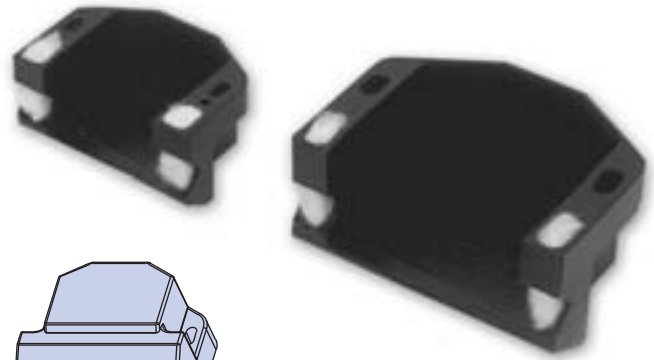

WHEEL COVER DIMENSIONS <sup>1</sup>									
Wheel Cover Profile	Size	Part Number	Length L	Mount Hole Spacing MHS	Height H	Fastener Height FH	Width W	Vee Height VH	Fastener S <sup>4</sup> & W <sup>4</sup>
<b>Standard Height</b> (for use with standard height metric bushings)	1	WC1A	35.6	30.5	18.0	8.1	22.9	10.3	M2 x 4 x 12
	2	WC2A	50.8	42.7	24.1	10.1	34.3	12.2	M3 x 5 x 16
	3	WC3A	67.8	59.4	34.0	15.3	50.2	17.5	M3 x 5 x 20
	4	WC4A	88.9	78.0	40.1	19.3	63.5	20.7	M4 x 7 x 25
<b>Low Profile</b> (for use with low profile height metric bushings)	1	WC1LPA	35.6	30.5	14.0	4.1	22.9	6.3	M2 x 4 x 8
	2	WC2LPA	50.8	42.7	19.6	5.6	34.3	7.7	M3 x 5 x 12
	3	WC3LPA	67.8	59.4	28.0	9.3	50.2	11.5	M3 x 5 x 16
	4	WC4LPA	88.9	78.0	32.1	11.3	63.5	12.6	M4 x 7 x 20
<b>Integral Wheel SWI BWI Bushing</b>	1	WC1SWI	38.0	31.8	13.3	1.4	24.4	7.3	M3 x 5 x 10
	2	WC2SWI	49.8	42.7	16.9		34.2	9.6	
	3	WC3SWI	67.3	59.4	23.2		50.0	13.6	M3 x 5 x 10
	4	WC4SWI	87.9	78.0	29.3		64.8	16.4	M4

**Notes:**

1. All dimensions in mm.
2. Wheel cover material is ABS black.
3. Felt material is white, pure wool, per specification SAE F-10 or ASTM 9R1.
4. Wheel covers are supplied complete with socket head cap screws and washers (stainless steel).
5. Please note there is no wheel cover option for sizes 0 and 4XXL.

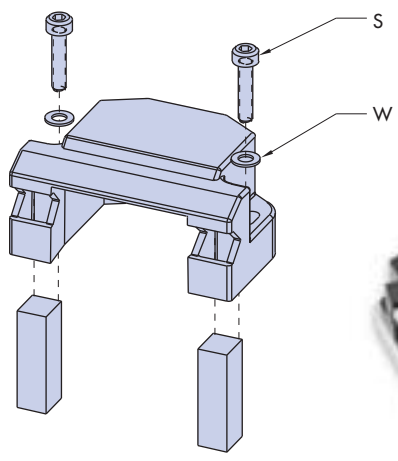



# Lubricator Assemblies

- Easy to install/available from stock
- Dispenses a thin film of oil along the Vee way<sup>3</sup>
- Lubricating properties increases load capacity and service life
- Stainless steel lubricator housing<sup>2</sup>

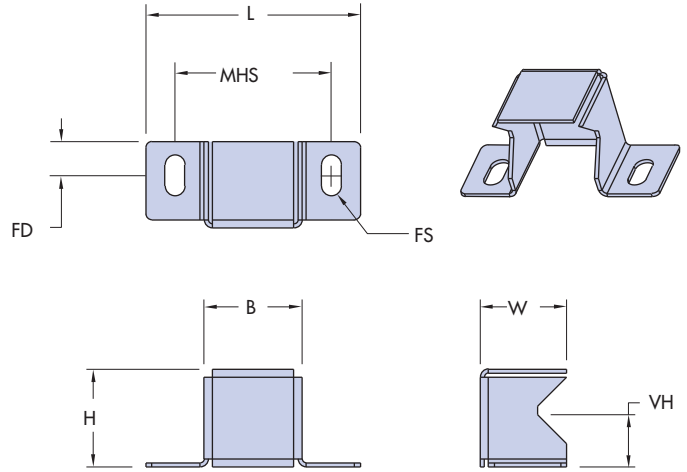

LUBRICATOR DIMENSIONS <sup>1</sup>										
Lubricator Profile	Dual Vee Size	Part Number	Overall Length L	Hole Spacing MHS	Body Length B	Height H	Width W	Vee Height VH	Fastener Hole Location FD	Fastener S <sup>4</sup> & W <sup>4</sup>
<b>MinVee</b>	0	MVOTL	17.8	12.0	5.84	9.14	7.62	4.32	2.92	M2 x .4 x 4
<b>Standard Height</b> (for use with standard height metric bushings)	1 & 2	TL12A	28.0	20.0	12.0	17.5	11.4	11.0	4.6	M3 x .5 x 6
	3 & 4	TL34A	46.7	34.0	21.3	30.5	18.8	19.1	7.4	M4 x .7 x 8
<b>Low Profile</b> (for use with low profile height metric bushings)	1 & 2	TL12LPA	28.0	20.0	12.0	13.5	11.4	7.1	4.6	M3 x .5 x 6
	3 & 4	TL34LPA	46.7	34.0	21.3	21.3	18.8	12.3	7.4	M4 x .7 x 8
<b>Integral Wheels</b> <b>SWI &amp; BWI</b>	1 & 2	TL12BWP	28.6	20.3	12.0	14.7	24.4	6.9	4.6	M3 x .5 x 10
	3 & 4	TL34BWP	46.7	34.0	21.3	25.8	34.2	13.0	7.4	M3 x .5 x 10 M4 x .7 x 10

**Notes:**

1. All dimensions in mm.
2. Lubricator housing material per specification ANSI 303, 304, or 316 stainless steel.
3. Felt material is white, pure wool, per specification SAE F-10 or ASTM 9R1.
4. Lubricators are supplied complete with socket head cap screws and washers (stainless steel).
5. Lubricator assembly for W4XXL, W4SSXXL is taken from our Heavy Duty Programme Part No HDLB 33J. This can only be used with Standard Profile Support bushings. Please request details.

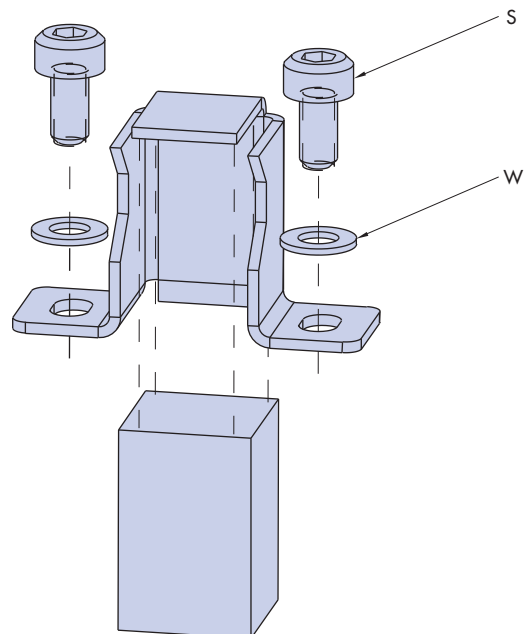

# Mounting Dimensions

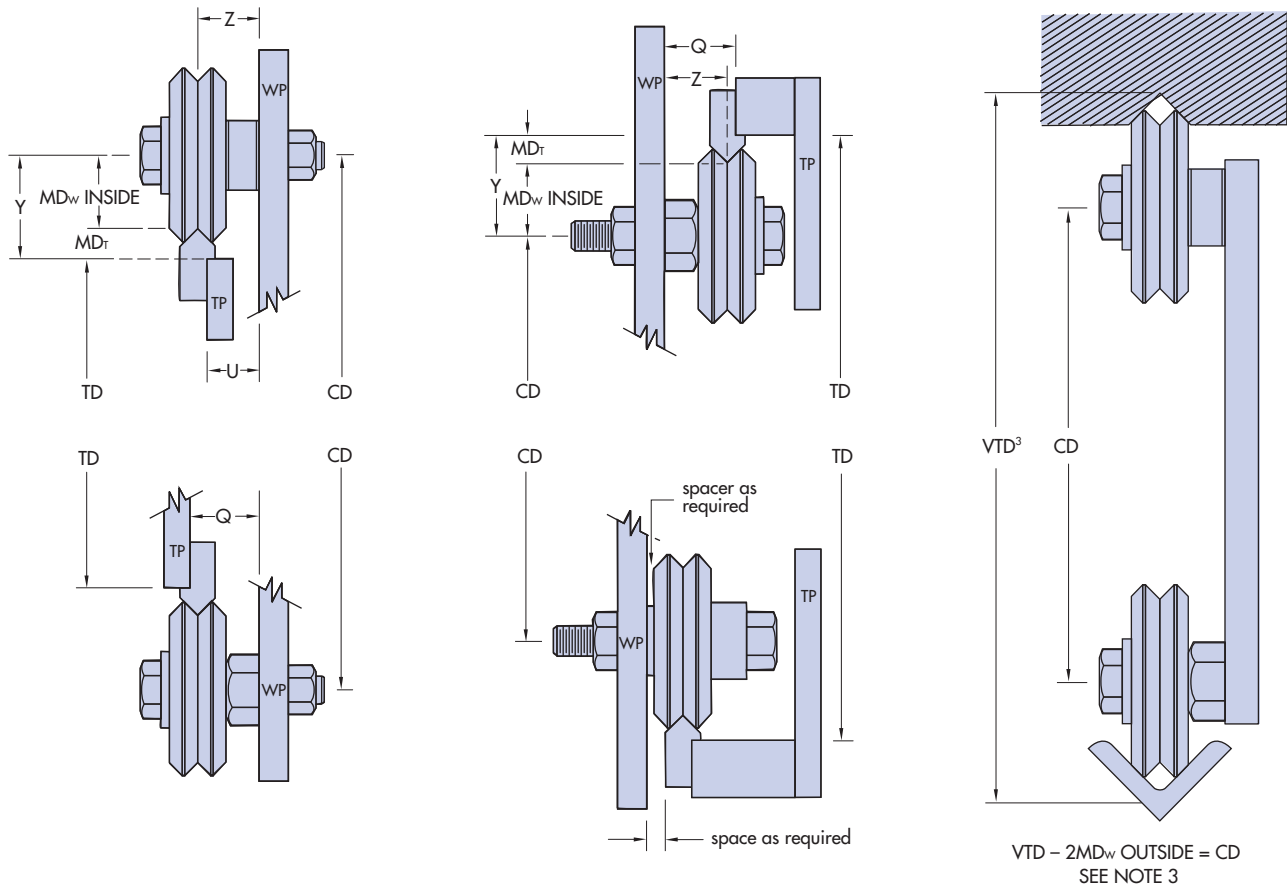

**outboard mounting formula**  $TD - 2 Y = CD$

**inboard mounting formula**  $TD + 2 Y = CD$

Where CD is less than wheel diameter, Guide Wheels must be offset for proper clearance.

## Legend

MD <sub>w</sub> outside = Mounting distance, wheel, using outside Vee (page 4)	WP = Wheel plate <sup>2</sup>
MD <sub>w</sub> inside = Mounting distance, wheel, using inside Vee (page 4)	TP = Track plate
MD <sub>T</sub> = Mounting distance, track (page 9)	Z = Distance from WP to centre of wheel
TD = Track distance	Q = Z + G (see page 10)
CD = Centre distance <sup>4</sup>	U = Z - G (see page 10)
Y = MD <sub>T</sub> + MD <sub>w</sub> inside	G = Distance from TP to centre line of track

## Dimensions<sup>5</sup> standard profile bushes

Size	Z	Q	U	Y
0	n/a	n/a	n/a	9.95
1	10.16	10.94	9.38	11.12
2	12.22	13	11.44	17.45
3	17.41	18.98	15.84	25.4
4	20.63	22.99	18.27	33.32
4XL <sup>1</sup>	27.05	29.41	24.69	39.67

## Dimensions<sup>5</sup> low profile bushes

Size	Z	Q	U	Y
0	n/a	n/a	n/a	9.95
1	6.05	6.83	5.27	11.12
2	8.21	8.99	7.43	17.45
3	11.42	12.99	9.85	25.4
4	12.63	14.99	10.27	33.32
4XL <sup>1</sup>	17.8	20.16	15.44	39.67

## Notes:

1. Data left uses the same size DualVee track and wheel except 4XL which uses W4XXL guide wheel with size T4 track.
2. It is recommended that wheel plates be constructed with concentric bushes on one side and eccentric on the other.
3. VTD dimension is the theoretical intersection of the 90° angle.
4. CD for double edge track size 0 and size 0 wheels = 24.98.
5. All dimensions are in mm.

### Load/Life Relationship

Several factors influence the service life of a DualVee linear system. Through research and development a simple method has been devised to estimate the load/life relationship for a specific DualVee guide mechanism under defined loading conditions. The methodology accounts for the size of the DualVee bearing elements, relative spacing, and the orientation, location, and magnitude of the load. The curve is based upon clean, well lubricated track conditions, so for applications where lubrication is prohibited, a derating factor must be applied.

It is important to note that secondary considerations such as maximum velocity, acceleration rates, duty cycle, stroke length, environmental conditions, the presence of shock and vibration, and extreme temperature ranges can all impact service life to varying degrees. As such, the sizing method outlined below should be used conservatively, and considered only as a guideline for the sizing of DualVee components and assemblies. When time and budget permits, the prototyping of a DualVee arrangement is recommended to confirm service life expectations.

### The Load/Life Equation — Sizing and Selection

The life of a DualVee guide will be limited to the life of the most heavily loaded bearing in the design.

**Step 1:** Calculate the resultant radial and axial loads reflected to each bearing element in the linear guide design.

If assistance is required in resolving specific loads into the resultant reaction forces at the guide wheel interface, contact our applications engineering staff for support. It is recommended that the Application Data Sheet on page 19 be submitted beforehand, with as much application information detailed as possible.

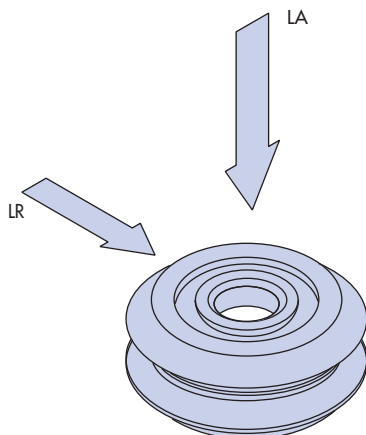

**Step 2:** Calculate the load factor for the most heavily loaded bearing.

$$LF = LA / LA_{max} + LR / LR_{max}$$

Where LF = Load Factor

LA = Resultant axial load on the guide wheel  
 LA<sub>max</sub> = The maximum axial working load capacity of the guide wheel

LR = Resultant radial load on the guide wheel  
 LR<sub>max</sub> = The maximum radial working load capacity of the guide wheel

- Bearings should be sized such that  $L_f \leq 1$
- The most heavily loaded bearing will have the highest load factor

Due to varying application load and speed parameters and environmental conditions, the appropriate adjustment factor must be applied to the maximum axial and radial working load capacities (LA<sub>max</sub> and LR<sub>max</sub>) as follows:

Adjustment Factor	Application Conditions
1.0-0.7	clean, low speed, low shock, low duty.
0.7-0.4	moderate contaminants, medium duty, medium shock, low to medium vibration, moderate speed.
0.4-0.1	heavy contamination, high acceleration, high speed, medium to high shock, high vibration, high duty cycle, dry running.

Oscillating motion resulting in less than one full revolution of the wheel under load can cause accelerated wear on the internal bearing elements. Testing of such systems is recommended to verify compatibility of the design with load/life requirements.

In lightly loaded applications bearing preload can be higher than the working load. A figure equivalent to 3% of the radial working load capacity should therefore be included in the LR figure when calculating life.

## DualVee Guide Wheel Load Capacities

LOAD CAPACITY (N)						
Part Number	Radial Working Load Capacity LRmax (N) <sup>2</sup>	Axial Working Load Capacity LAmax (N) <sup>2</sup>	BDLR <sup>1</sup> Radial (N)	BSLR <sup>1</sup> Radial (N)	BDLR <sup>1</sup> Axial (N)	BSLR <sup>1</sup> Axial (N)
W0	650	123	1050	500	530	470
W1	1220	252	2180	1110	1090	1040
W2	2650	625	4700	2780	2380	2630
W3	5900	1701	9150	5050	4500	4800
W4	9700	4001	12800	7900	6350	7450
W0X	650	123	1050	500	530	470
W1X	1220	252	2180	1110	1090	1040
W2X	2650	625	4700	2780	2380	2630
W3X	5900	1701	9150	5050	4500	4800
W4X	9700	4001	12800	7900	6350	7450
W4XXL	14300	6552	20600	14300	10400	13500
W1SSX	1220	252	2180	1110	1090	1040
W2SSX	2650	625	4700	2780	2380	2630
W3SSX	5900	1701	9150	5050	4500	4800
W4SSX	9700	4001	12800	7900	6350	7450
W4SSXXL	14300	6552	20600	14300	10400	13500
W0SSCR	540	102	872	415	440	390
W1SS227	1013	208	1810	920	900	870
W2SS227	2200	520	3900	2310	1980	2180
W3SS227	4897	1399	7600	4200	3700	4000
W4SSCR	8051	3320	10600	6560	5270	6180

**Step 3:** Apply the load factor to the load/life equation below:

$$\text{Life (in Km)} = \text{LC} / (\text{LF})^3$$

Where LF = Load Factor

LC = Life Constant

Life constants are provided as tabulated below.

LOAD/LIFE CONSTANTS	
DualVee Size	LC
0	41
1	55
2	87
3	130
4	171
4XL	215

**Notes:**

1. The BDLR (Basic Dynamic Load Rating) and BSLR (Basic Static Load Rating) are according to AFBMA STD 9-1990. These ratings are based on industry standard bearing calculations and are for comparison to other products as measured against the same standard. Working load capacities should be used for component sizing and selection.
2. Sizing and selection should be based on working load capacity ratings according to the sizing guidelines presented in the technical reference section. (See page 17)
3. Working load capacities reflect lubricated wheel/track interface. Wheel covers will provide this function together with preventing the ingress of dirt. Lubricator assemblies will provide an equally effective lubrication means.

## DualVee – Overview

### Lubrication

Lubrication is the key to maximising the life of a DualVee linear guide. Internally, DualVee guide wheels are lubricated for life with an extreme pressure, corrosion resistant grease. However, lubrication of the wheel/track interface is the responsibility of the user. A light machine oil or an extreme pressure grease will serve well in minimising wear, stick slip, and corrosion on the guide ways in a DualVee-based design. Lubrication will maximise the load capacity of an individual bearing element. As such, for any specific application loading condition, the presence of lubrication on the guide ways will significantly increase the service life over a non-lubricated configuration under the same loads.

Lubrication will also increase the maximum linear velocity that a DualVee bearing arrangement can endure. In applications where high speed or high acceleration rates are present, lubrication of the wheel/track interface is highly recommended. Lastly, lubrication will reduce the overall coefficient of friction of the guide, which, depending on the level of preload, can fall anywhere from 0.008 to 0.015. The availability of lubricators and wheel covers gives design engineers an opportunity to design lubrication right into the DualVee mechanism with little effort. See specifications on wheel covers and lubricators for more detail.

### Track Butting Considerations

Precut lengths of track are not suitable for butting end to end. Please contact the factory when track lengths longer than the maximum available single piece lengths are required, so that the ends can be specially prepared. When constructing track systems longer than 6 metres, the joints on parallel tracks should be staggered for greater accuracy and smoothness.

### Track Hardening

For most applications, and to ensure greater resistance to wear, the 'T' series hard edge track should be used. The lower cost 'TS' soft track is suitable only for light duty, light load applications.

### Contamination/Wear Resistance

Since the circumference of the wheel is greater at the major diameter than at the minor diameter, there is a constant wiping action on the track producing a self cleaning effect. As such, DualVee guide wheels are employed in a wide variety of harsh environments, including the presence of metal chips, powders, fibres, slurries, etc. It is important to note that such environments will often limit the service life of a DualVee linear guide to some extent. Since environments vary from application to application, it is recommended that DualVee systems be prototyped before employing on a large scale. As an example, an OEM who is building a paper processing machine may want to prototype a linear guide in applications where the guide ways are exposed to unique combinations of chemicals and paper fibres. It's difficult to predict exactly how the materials will behave in many cases.

For instance a fine, yet hard powder material may accelerate wear in one case but simply be swept aside in another, depending on parameters such as particle size, temperature, humidity, and lubrication. Regardless, DualVee is clearly the choice of antifriction linear guide technology in difficult environments, particularly when success is mandatory and reliability is critical.

The other main factor affecting wear resistance is lubrication. Wheel covers or lubricators should be designed in whenever possible. Both will distribute a thin coating of oil lubricant along the contact surface of the DualVee track. The wheel covers offer added protection by preventing debris from entering the wheel/track contact surface. Lubricated and relatively clean wheel/track contact surfaces will ensure maximum service life in a DualVee linear guide.

## DualVee - Overview

### System Adjustment

The stationary bushings determine the alignment of the system. They should carry the major load whenever possible. It is also good practice to configure the wheels so that the load is predominantly radial.

Normal adjustment is obtained by rotating the eccentric bushings until all free play is removed from the carriage assembly. When the eccentrics are adjusted and the carriage plate is held firmly in place, it should be possible to rotate, by hand, any of the four guide wheels in the system against its mating track. If rotation is not possible, preload on the wheels should be reduced accordingly. Overtightening of the eccentric adjustment could result in premature bearing failure. Such a condition can exert a force greater than the load rating of the wheel.

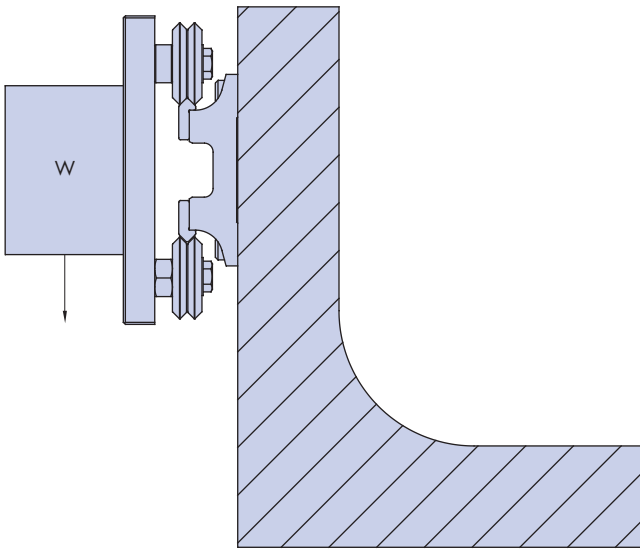

**Figure 9:** Linear guide configured primarily radial load.

### Wash Down Environments

For wash down applications, pillars can be used to mount track to a mounting surface, eliminating dirt traps, and allowing for washdown (see sketch below).

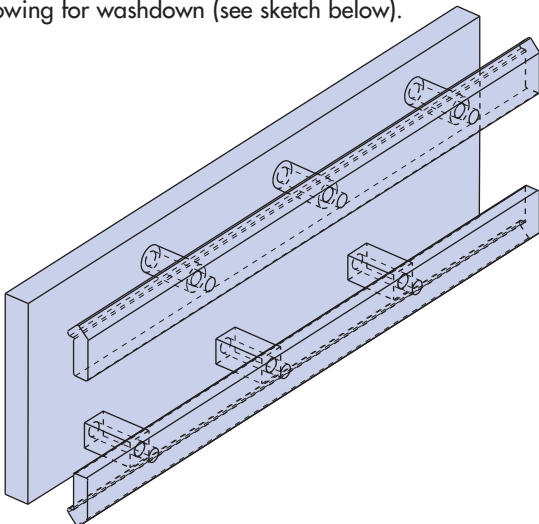

**Figure 10:** DualVee track mounted with pillars eliminates dirt traps.

### Clean Room Products

Clean room compatible guide wheels are manufactured from 440C stainless steel bearing elements, and contain stainless steel retainers and shields. They are internally lubricated with synthetic, corrosion resistant, clean room-compatible grease.

For clean room operation, it is often desirable to plate the track with thin dense chrome (TDC), black oxide, or electroless nickel. Stainless steel track can also be specially cleaned prior to heat treat and then passivated. Contact Hepco applications engineering for assistance with your clean room linear guidance questions. Higher level assemblies, custom engineered to accommodate specific clean room requirements, can be furnished by Hepco. Contact Hepco Application Engineers for particle emissions data.

### High Temperature Products

All Hepco high temperature guide wheel products are manufactured from specially processed, thermally stabilised, 440C stainless steel. Lubricated with a specially formulated synthetic grease, these guide wheels are capable of operating in temperatures up to 260°C. Special consideration should be given to guide wheel-based designs when operating above temperatures of 150°C. Designers must make sure that a suitable lubricant is used on the wheel track interface, and if lubrication is prohibited, the appropriate derating of the bearing should be factored in.

## Quick Ordering Procedure

DualVee has a number of options for wheels, track, bushes, wheel covers etc. to cater for a wide variety of demanding applications. However, most applications for DualVee are relatively simple with no particular load or environmental requirements. In these cases a basic system of 4 standard wheels and track will suffice and the following example selects the more popular options.

### Wheels (pages 3&4)

Select standard wheels W1, W2, W3, W4 (alternatively select the lower cost Integral Bushing or studded Wheel option – page 5).

### Bushes for use with Wheels (page 12&13)

Select appropriate size concentric bushing to match wheel MB1, MB2, MB3, MB4 if not using Integral Bushing Wheel.

**Note:** with a conventional 4 wheel arrangement it is normal to have 2 concentric wheels on one side and two eccentric on the other side.

### Track (pages 9, 10&11)

Select hardened track to match T1, T2, T3 or T4, we will cut to the length you require or alternatively track can be supplied with drilled fixing holes T1D, T2D, T3D, T4D.

### Ordering Example

4 pcs W4 Wheels	}	or	2pcs BWIC4 Integral Wheel – Conc
2 pcs MB4 Concentric Bushes			2pcs BWEC4 Integral Wheel – Ecc
2 pcs MBX4 Eccentric Bushes			2pcs T4 Track x 2000mm long
2 pcs T4 Track x 2000mm long			

## Full Size Drawings

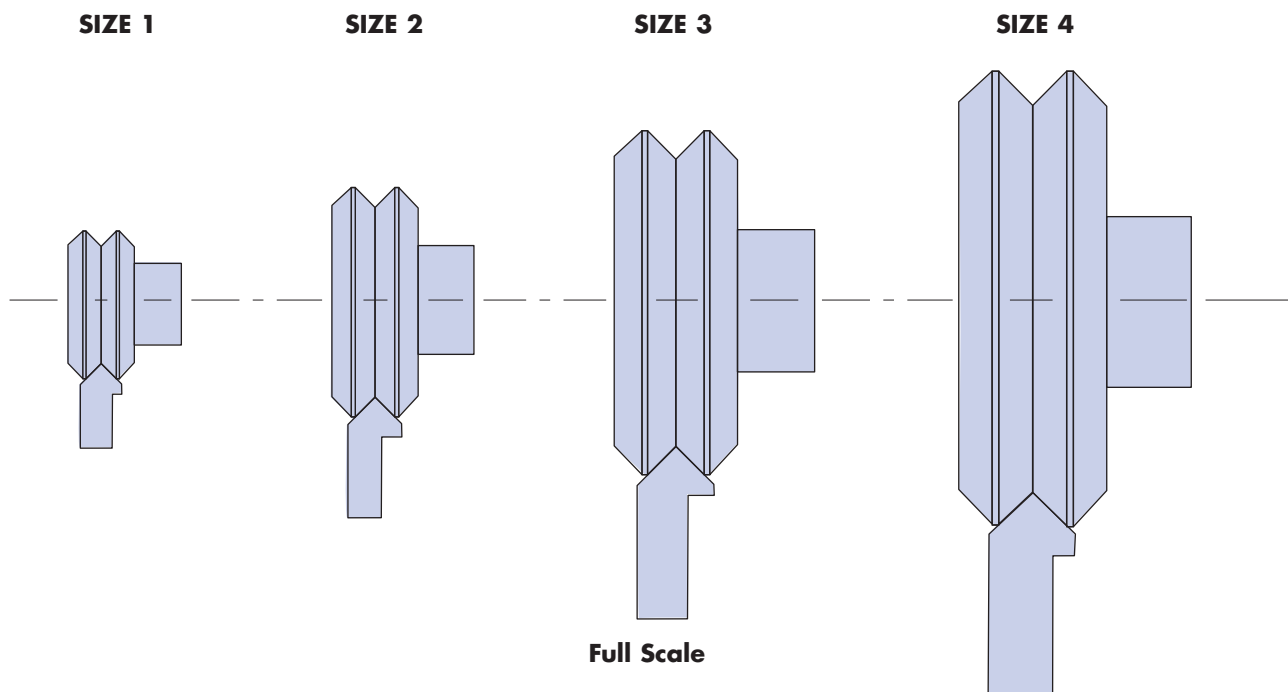

Selection of the appropriate size wheel/track for a given application is often made initially by reference to the physical size of the product as opposed to load capacity.

These full size sections will help with the selection process prior to checking the load/life which can be checked on pages 17/19.

Full size drawings for sizes '0' and '4XXL' are available on request.

# MinVee™ Linear Slide Systems

MinVee™ is a low profile, miniature slide system suitable for use in laboratory, medical and semi-conductor applications.

## Wheel Carriage

### (4) Size 0 DualVee® Wheels

- (2) Concentric (2) Eccentric
- Carbon Steel or Polymer over-molded stainless steel
- Double row angular contact bearings, AISI 52100
- Integral stud shaft design

### Carriage Anodized Aluminum 6061-T5

- Stainless steel lubricator housing
- Felt lubrication pads

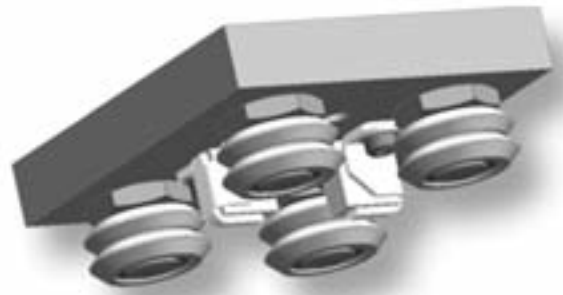

## Wheel Carriage Models

<b>MVOWPA</b>	Wheel carriage with steel wheels with shielded bearings
<b>MVOWPAX</b>	Wheel carriage with steel wheels with sealed bearings
<b>MVOWPAP</b>	Wheel carriage with polymer wheels with shielded bearings

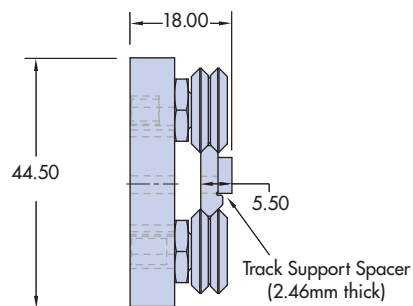
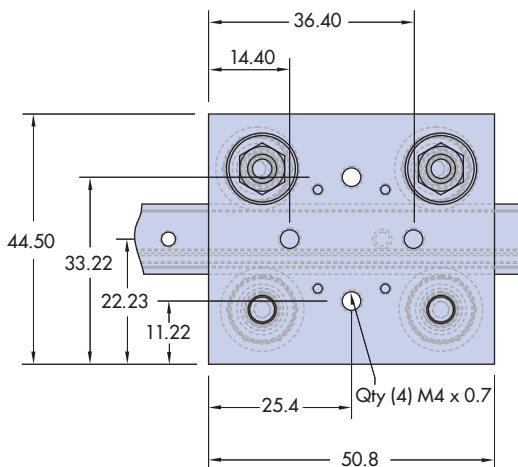



# MinVee™ Linear Slide System

## Track Size 0



**Double Edge Design ensures Parallel Vee Ways**  
**Patented Mounting Shoulder, Accurate Vee Ways Position**  
**Carbon Steel AISI 1045**

- Hardened (Rc 53) polished
- Unhardened (Rc 22-25)

## Size 0 Track with Pre-Drilled Mounting Holes

Model	Length (mm) L	Number of Holes
TDO-155-4	155	4
TDO-290-7	290	7
TDO-425-10	425	10
TDO-560-13	560	13
TDO-695-16	695	16
TDO-830-19	830	19

\*For longer lengths see page 12 or contact HepcoMotion.

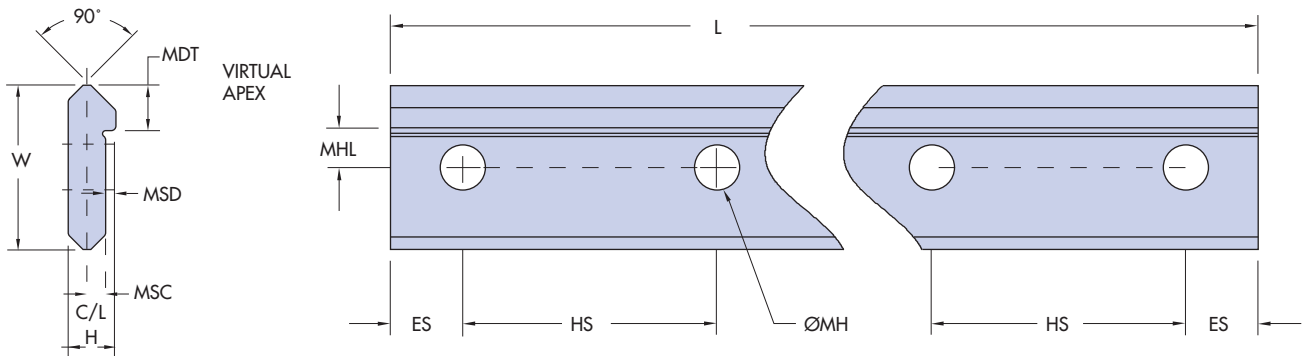

W	H	MDT	MSC	MSD	ES	HS <sup>2</sup>	MH	MHL	L <sup>1</sup>
13.10	3.89	4.01	1.52	0.83	10	45	4.00	2.56	Mode Code Table

### Track Options:

- Non standard track lengths optional up to 6m.
- Custom coating/plating are black oxide or Thin Dense Chrome.

### Notes:

1. The overall length tolerance is  $\pm 0.1$  mm
2. Hole spacing tolerance is  $\pm 0.127$  mm

## Load, Speed, Life

Load Capacity – Based on 100km Life

Wheel Carriage Type	Axial Working Load	Radial Working Load	Pitch Moment	Yaw Moment	Roll Moment
	$L_A$	$L_R$	$M_P$	$M_Y$	$M_R$
Size 0 Steel	965 N	365 N	5.8 Nm	15.3 Nm	4.5 Nm
	Maximum Speed 5m/sec Maximum Acceleration 49m/sec <sup>2</sup>				
Size 0 Polymer	44 N	65 N	1.4 Nm	4.5 Nm	1 Nm
	Maximum Speed 1m/sec Maximum Acceleration 29.4m/sec <sup>2</sup>				

Life Calculation:

$$L_f = \frac{L_r}{L_{r \max}} + \frac{L_A}{L_{A \max}} + \frac{M_P}{M_{P \max}} + \frac{M_Y}{M_{Y \max}} + \frac{M_R}{M_{R \max}}$$

$$\text{Life (steel) (km)} = \frac{100}{(0.9L_f + 0.1)^3} \quad @ L_f < 1$$

$$\text{Life (polymer) (km)} = \frac{100}{0.9L_f + 0.1} \quad @ L_f < 1$$

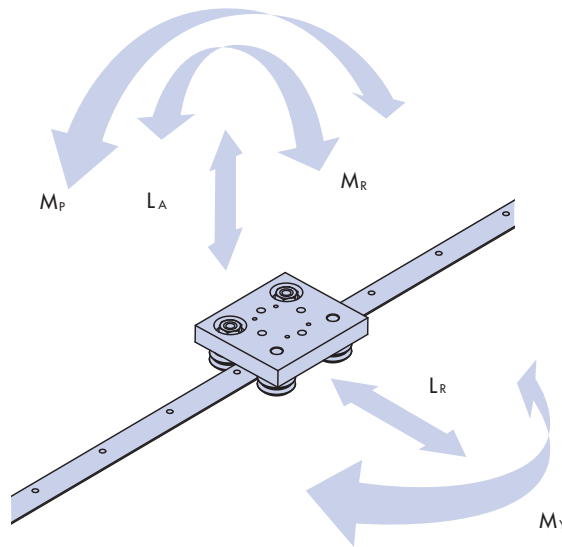

### Temp. Range:

-20° C to +120° C

## How to Order

1. Wheel Carriage: Quantity and Model (eg. 1 x MVOWPA – Carriage Steel Wheels Shielded)
2. Track: Standard Lengths (eg. 1 x TDO-290-7 – Track length 290mm, with 7 holes)
3. Track Support Spacers: Part # MV0S18H, 303 Stainless Steel 2.46mm High (1 per mounting hole) (x7)



# HepcoMotion® Product Range



## Bishop-Wisecarver Product Range

HepcoMotion® – Exclusive European partners and distributors for Bishop-Wisecarver since 1984.

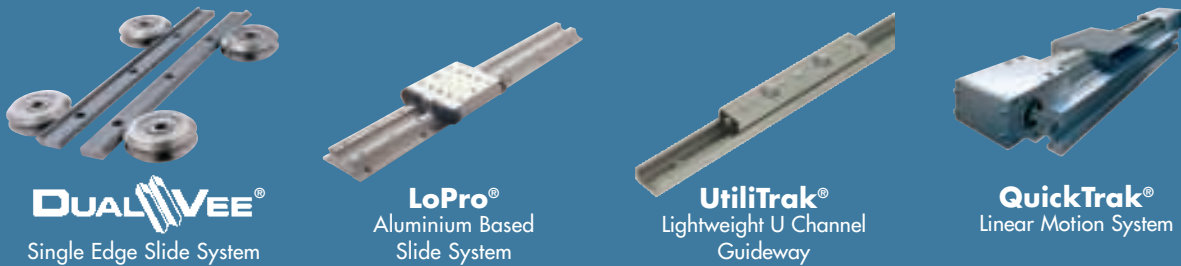

For further information on HepcoMotion® products – please request our leaflet 'FPL'



**HepcoMotion®**

Lower Moor Business Park, Tiverton Way, Tiverton, Devon, England EX16 6TG  
Tel: +44 (0)1884 257000 Fax: +44 (0)1884 243500  
E-mail: sales@hepcotion.com

CATALOGUE No. DV 08 UK © 2007 Hepco Slide Systems Ltd.

Reproduction in whole or part without prior authorisation from Hepco is prohibited. Although every effort has been made to ensure the accuracy of the information in this catalogue, Hepco cannot accept liability for any omissions or errors. Hepco reserves the right to make alterations to the product resulting from technical developments.

Many Hepco products are protected by: Patents, Copyright, Design Right or Registered Design. Infringement is strictly prohibited and may be challenged in law. The Customer's attention is drawn to the following clause in Hepco's conditions of sale:

'It shall be the Customer's sole responsibility to ensure that goods supplied by Hepco will be suitable or fit for any particular application or purpose of the Customer, whether or not such application or purpose is known to Hepco. The Customer will be solely responsible for any errors in, or omissions from, any specifications or information the Customer provides. Hepco will not be obliged to verify whether any such specifications or information are correct or sufficient for any application or purpose.'

Hepco's full conditions of sale are available on request and will apply to all quotations and contracts for the supply of items detailed in this catalogue. HepcoMotion is the trading name of Hepco Slide Systems Ltd.



INVESTOR IN PEOPLE

